

Question No: 1 ( Marks: 1 ) - Please choose one

If we connect 3 capacitors in series, the combined effect of all these capacitors will be

- ▶ equal to the sum of individual capacitors
- ▶ the sum of reciprocals of individual capacitors **Page 22**
- ▶ zero
- ▶ product of all



Question No: 2 ( Marks: 1 ) - Please choose one

A node which emerges as a result of combination of two ordinary nodes is called

- ▶ Heavy node
- ▶ Simple node
- ▶ Super mes
- ▶ Super node Page 52

Question No: 3 ( Marks: 1 ) - Please choose one

Unit of inductance is

- ▶ mho
- ▶ ohm
- ▶ Henry page 19
- ▶ Farad

Question No: 4 ( Marks: 1 ) - Please choose one

Reciprocal of resistance is

- ▶ Conductance
- ▶ Inductance
- ▶ Capacitance Page 22
- ▶ Resistivity

Question No: 5 ( Marks: 1 ) - Please choose one

An ideal voltage source is a circuit element where the voltage across it is independent of

- ▶ resistance
- ▶ current Page 26
- ▶ capacitance
- ▶ inductance

Question No: 6 ( Marks: 1 ) - Please choose one

Sum of all currents entering in the node is equal to sum of currents leaving the node, is statement of

- ▶ Ohm's law
- ▶ Kirchhoff's current law LECTURE 7
- ▶ Jaime's law
- ▶ Rutherford's law

**Question No: 7 (Please choose one)**

---

Which current source will be used for super mesh?

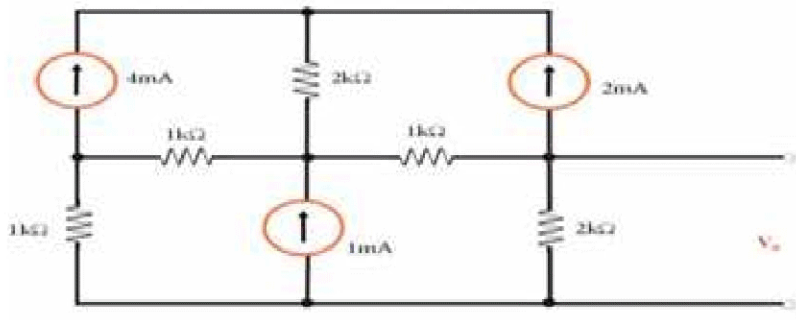

▶ 4mA

▶ 2mA

▶ 1mA when two meshes share current source then it became super mesh

▶ 2mA and 4mA

Question No: 8 - Please choose one

How many KVL equations can be written for the given circuit?

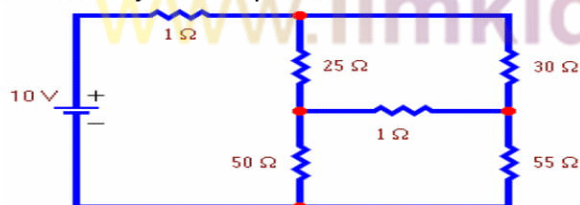

▶ 2

▶ 4

▶ 3 because 3 meshes or loops are formed and number of loops is equal to number of equations.

▶ 1

**Question No: 9 - Please choose one**

For the given circuit, voltage  $V_{DF}$  is

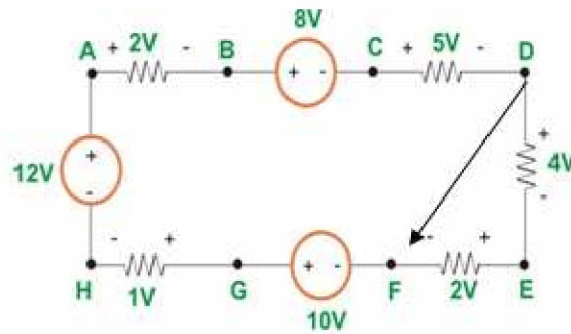

- ▶ 6v
- ▶ 2v
- ▶ 4v
- ▶ 10v

**Question No: - Please choose one**

If a parallel circuit is open in main line, the current

- ▶ increases in each branch
- ▶ is zero in all the branches
- ▶ is zero only in the branch that has highest resistance
- ▶ increases in the branch that has lowest resistance.

**Question No: 11 - Please choose one**

How many loop equations can be written for this circuit?

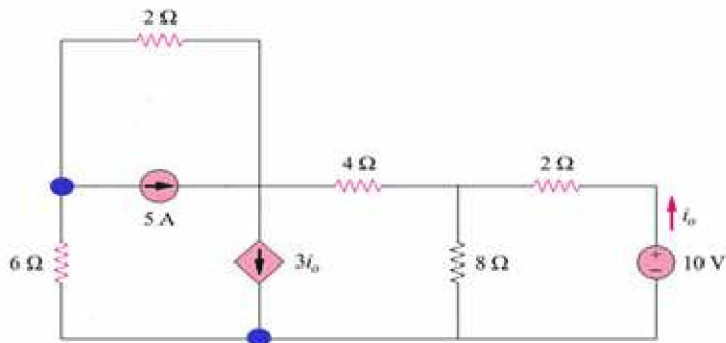

▶ 2

▶ 4

**LOOP**

It is the closed path for the flow of current in which no node is encountered more than once.

▶ 3

▶ 5

Question No: 12 ) – Please choose one

How many sources are dependent sources in given circuit?

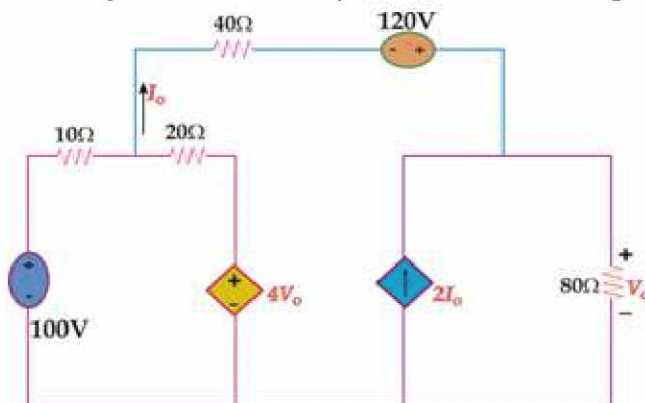

▶ 3

▶ 2

▶ 4

▶ 1

**Question No: 13 - Please choose one**

How many loops can be assigned to given figure?

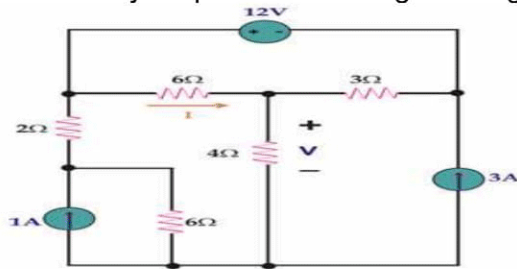

▶ 2

▶ 4

▶ 3

▶ 5

**Question No: 14 - Please choose one**

Through which resistance most current will flow

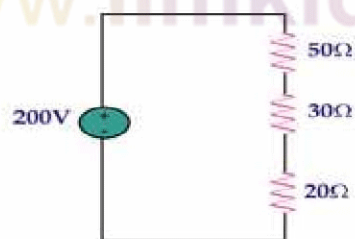

▶ 50Ω

▶ 30Ω

▶ 20Ω

▶ same through all resistance Because same current flowing through series combination. Page 32

**Question No: 15 - Please choose one**

In given circuit power dissipated across each bulb is 20w. What would be the resistance of each bulb.

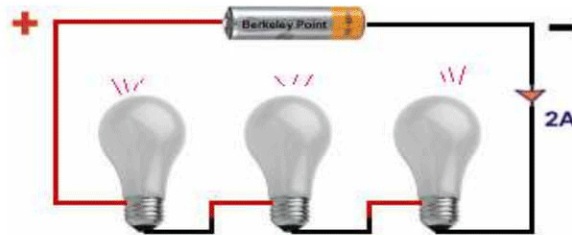

► 5Ω

$$\begin{aligned} P &= V \cdot I \\ 20 &= V \cdot 2A \\ 20/2 &= V \\ V &= 10v \\ \text{So,} \\ R &= V/I = 10/2 = 5 \text{ ohm} = \text{Ans.....} \end{aligned}$$

- 10Ω
- 40Ω
- 20Ω



**Question No: 16 - Please choose one**

In the figure below Voltage drop across 7Ω will be

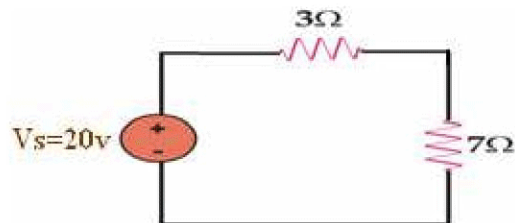

► 20v

▶ 14v

$$V = R/RT * VS$$

So,

$$V = 7/10 * 20 = 14V$$

▶ 6v

▶ 10v

**Question No: 17 - Please choose one**

---

If current flowing through  $4\Omega$  is 1Ma, voltage drop across it will be

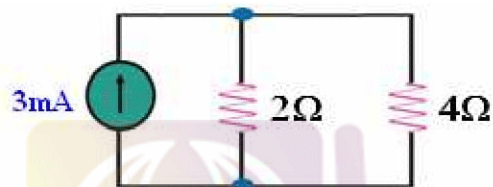

▶ 2V

▶ 6V

▶ 4V not sure

▶ 12V

**Question No: 18 - Please choose one**

---

For the given figure current flowing through  $5\Omega$  is

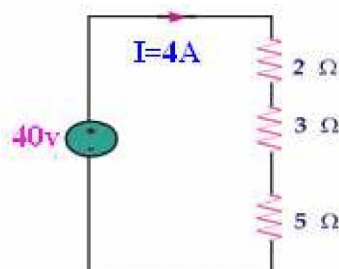

▶ 5A

▶ **4A** same current will flow in series circuit.

▶ 10A

▶ 2A

**Question No: 19 - Please choose one**

The value of  $I_a$  for given circuit is

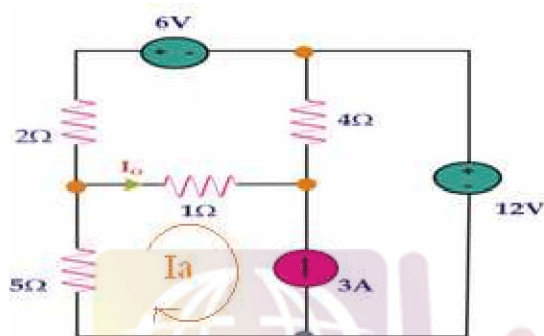

▶  $I_a = I_0$

▶  $I_a = 3A$

▶  **$I_a = -3A$**  Current is not in same direction with 3A.

▶  $I_a = 6v$

**Question No: 20 - Please choose one**

In the given circuit the value of independent current source is

